

High Reliability Hyperboloid Contacts

ICO SERIES

integra
MateTM



integraMate Hyperboloid Contacts



QA Technology **integraMate™ Contacts** are high quality, high reliability hyperboloid contacts intended for use in a wide range of applications. Our patented design provides lower insertion force, closer connector pin spacing, and better protection from damage than competitive designs. In addition, our automated manufacturing equipment typically allows us to ship within 24-48 hours of order.

Competitive Advantages

The integraMate Hyperboloid Contact System has three clear advantages over existing hyperboloid contacts:

1. Lower and more uniform insertion and extraction force
2. Smaller contact diameter allows closer spacing and higher connector density
3. Better protection of the hyperbolic wire cage from accidental damage, since the cage lies behind a strong tubular entrance

Features

- Low insertion/extraction force
- Low resistance
- Long cycle life
- Resistance to shock and vibration*
- Positive wiping action
- Easy contact removal using available extraction tools
- Small external contact diameter compared to other hyperboloid contacts allowing closer spacing
- Tubular entrance to protect spring wire cage and guide mating
- Intermates with other hyperboloid contacts known in the industry

Applications

High reliability connectors for:

- Medical & Dental Equipment
- Scientific Instruments
- Industrial Equipment
- Transportation Equipment
- ATE Interfaces
- Military & Aerospace
- Telecommunications & Data Communications

* Contacts have been tested while installed in integraMate circular connectors for resistance to vibration, shock, humidity, and corrosion. For details and test results, please contact QA.

Socket Construction Details

0.6mm Signal Contacts Type ICO60

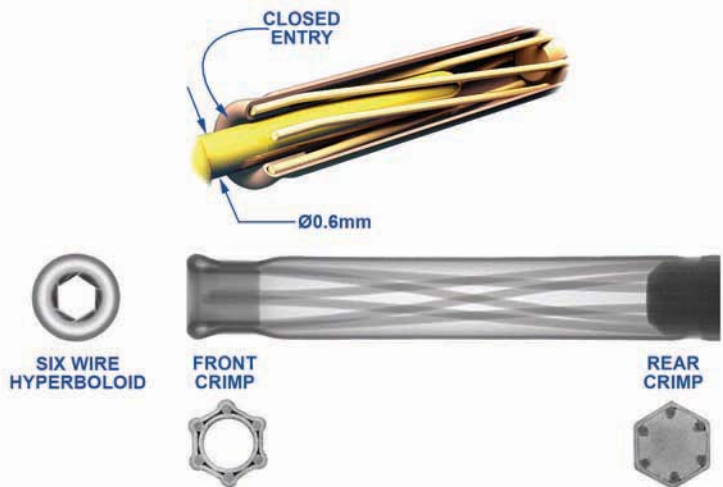

1.5mm Power Contacts Type ICOA5

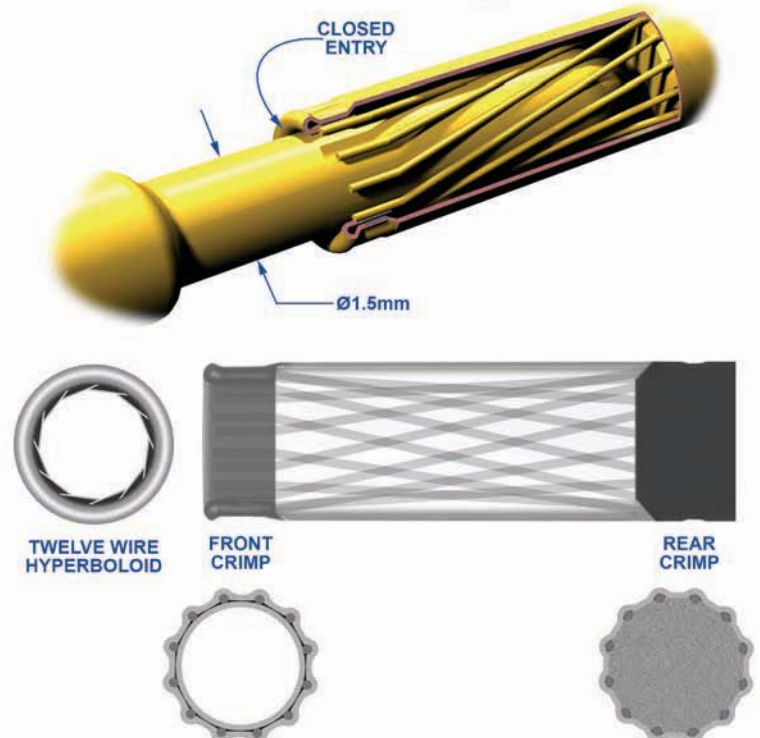

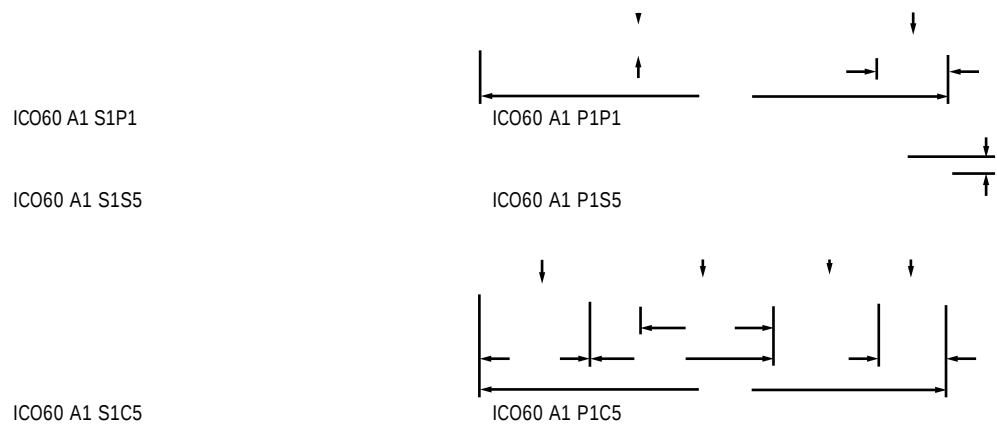

IC060 Pin / Socket Engagement Lengths

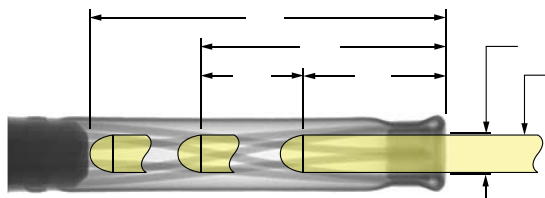

1.5mm Power Contacts Type ICOA5

SOCKETS

PINS

Solder Cup Termination

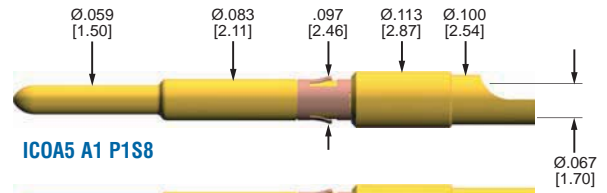
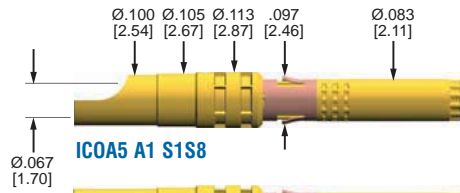

Crimp Termination

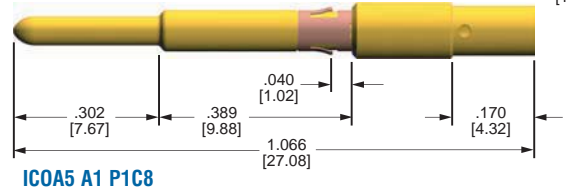
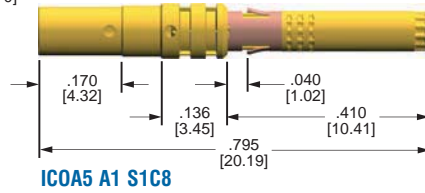

Actual Size



Specifications

Mechanical	Specification
Insertion/Extraction Force	4 oz [114 g] typical
Retention Force	5.0 lb [22.2 N]
Durability (Cycle Life)	Up to 100,000 Cycles
Electrical	
Current Rating	12.0 Amps nominal (dependent upon mounting config., contact density, ambient temp., etc.)
Contact Resistance	2 milliohms maximum, 1.5 milliohms typical
Wire Size	16 – 20 AWG Crimp & Solder Cup
Materials	
Contact Wires	Beryllium Copper, ends not plated
Spring Clip	Beryllium Copper, not plated
All other parts	High conductivity copper alloys
Plating	<ul style="list-style-type: none"> • 50 μ-inch of gold plating over nickel on all sliding contact surfaces • 10 μ-inch minimum of gold plating over nickel on all other surfaces, except as noted

ICOA5 Pin / Socket Engagement Lengths

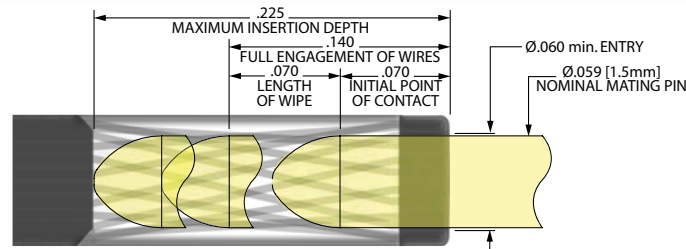

Typical Dimensions for Mounting in Insulator

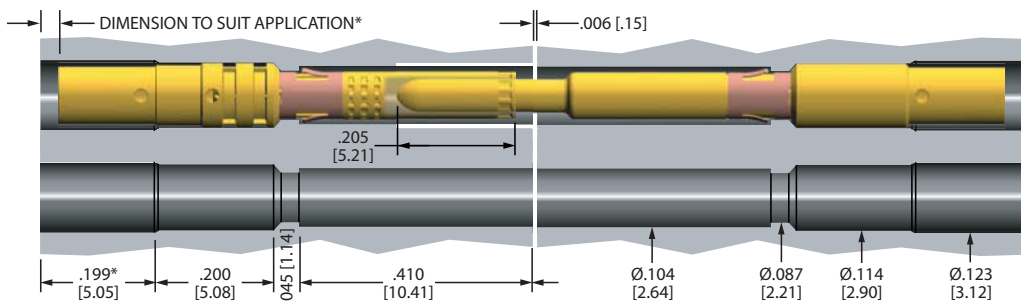

All specifications subject to change without notice. All dimensions are in inches [mm]

integraMate™ Hyperboloid Contact Ordering Information

0.6mm Contact Order Code:

I C O 6 0

A 1

1

Contact Type	Termination Type	Wire Size
P Pin	P PCB	1 Ø .024 Solder Tail
S Socket	C Crimp	5 22-26 AWG
	S Solder Cup	

1.5mm Contact Order Code:

I C O A 5

A 1

1 8

Contact Type	Termination Type	Wire Size
P Pin	C Crimp	8 16-20 AWG
S Socket	S Solder	

Accessories and Tools for ICO60 (0.6mm) Contacts

ITC-100	Crimping Tool – Daniels AFM8 crimping tool (contact positioner not included)
ITP-O60	Contact Positioner – Positions 0.6 mm contacts in Daniels AFM8 crimping tool
ITE-O60	Contact Extraction Tool – Extracts 0.6 mm contacts from dielectric

Accessories and Tools for ICOA5 (1.5mm) Contacts

ITC-200	Crimping Tool – Daniels AF8 crimping tool (contact positioner not included)
ITP-OA5	Contact Positioner – Positions 1.5 mm contacts in Daniels AF8 crimping tool
ITE-OA5	Contact Extraction Tool – Extracts 1.5 mm contacts from dielectric



ITC-100 & ITC-200 Crimping Tools



ITP-O60 Positioner
for 0.6 mm Contacts



ITP-OA5 Positioner
for 1.5 mm Contacts



ITE-O60 Extraction Tool
for 0.6 mm Contacts



ITE-OA5 Extraction Tool
for 1.5 mm Contacts

About QA Technology

QA Technology was founded in 1981 and has since been recognized as a worldwide leader in the manufacture of high quality spring contact test probes. QA designs and builds its own flexible, high-speed automatic assembly equipment, which allows us to typically ship orders within 24-48 hours. Now QA Technology brings the same high quality and manufacturing speed to the hyperboloid contact market.



integra
Mate™

 **Technology Company, Inc.**

110 Towle Farm Road
Hampton, NH 03842 USA
Tel: 603.926.1193
Fax: 603.926.8701

www.qatech.com/integramate

© 2007 QA Technology, Inc. All Rights Reserved.